

Directional control valve ZC100 is PC100 with direct solenoid control.
 Sections ZC100 uses PC100 body with additional machining.
 ZC100 sections can be assembled in Bank with PC100 and PC70 sections.

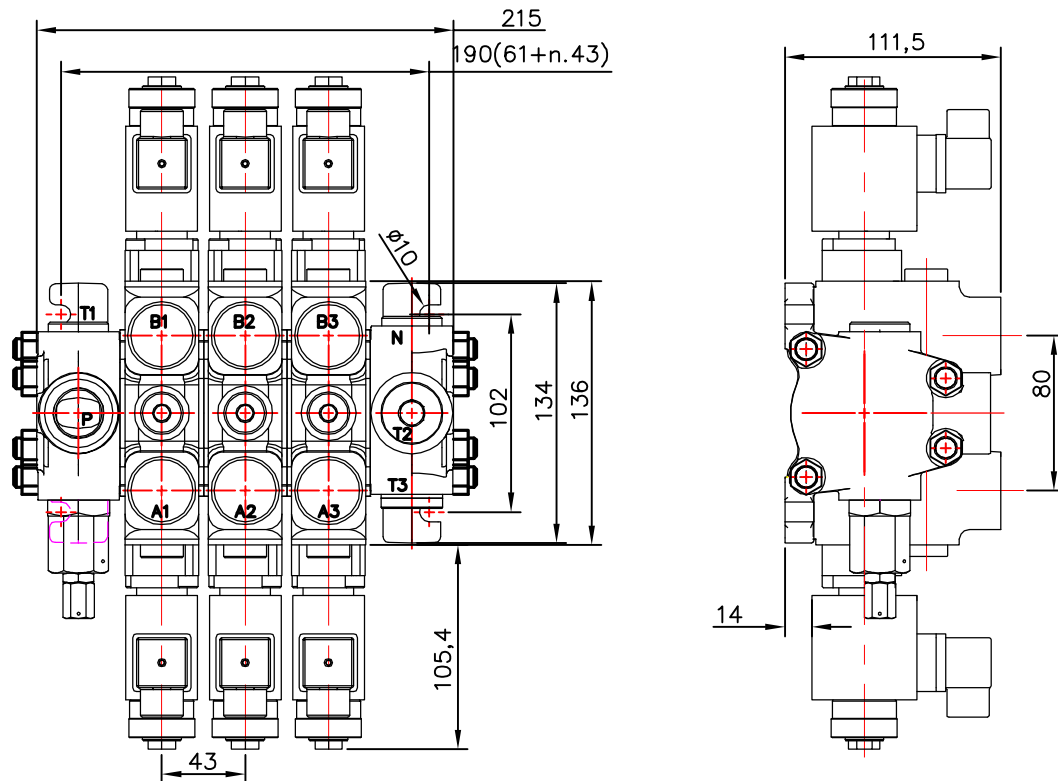

nom. operating pressure P=210 bar; A,B=250 bar; T<50 bar
 pressure medium – mineral hydraulic oil
 20 ... 100 mm /s recommended range
 max flow – 100 l/min (see "operating " diagram)
 nominal flow – 80 l/min (see "operating " diagram)
 n – number of Sections per Valve Bank– max 10
 Структура обозначения распределителя
 Order code

3 ZC100 R N2 /AES3(AzBx) /AES3 /DES3 /T2 / G C2

количество золотников number of spools	3
распределитель типа directional control valve	ZC100 R
вход давления с правой стороны inlet high pressure – right	N2
тип напорной секции type of the inlet cover	/AES3(AzBx)
характеристика первого золотника first spool distribution type	/AES3
характеристика второго золотника second spool distribution type	/DES3
характеристика третьего золотника third spool distribution	/T2
тип сливной секции (T) type of the outlet cover (T port)	/ G
размер присоединительных отверстий threads (P, A, B, T, N) продолжитель потока high pressure carry over	C2

параллельное распределение

parallel circuit

3ZC100 N2 / AES3(AzBx) / AES3 /DES3 /T2

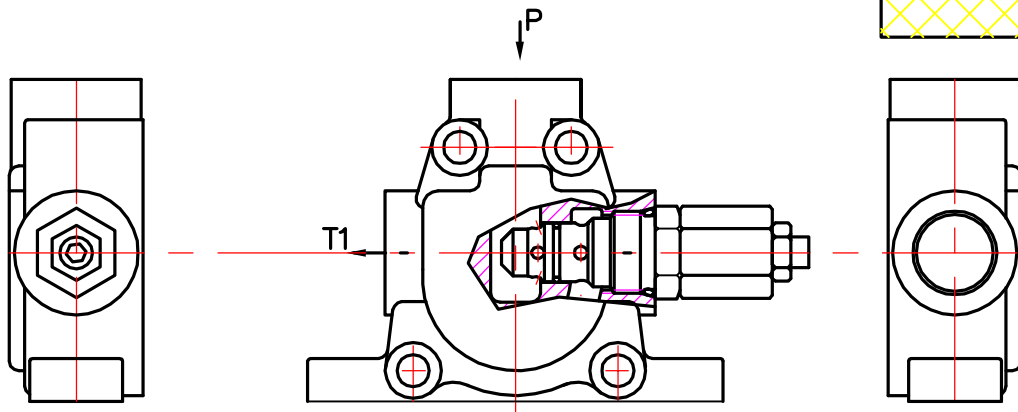
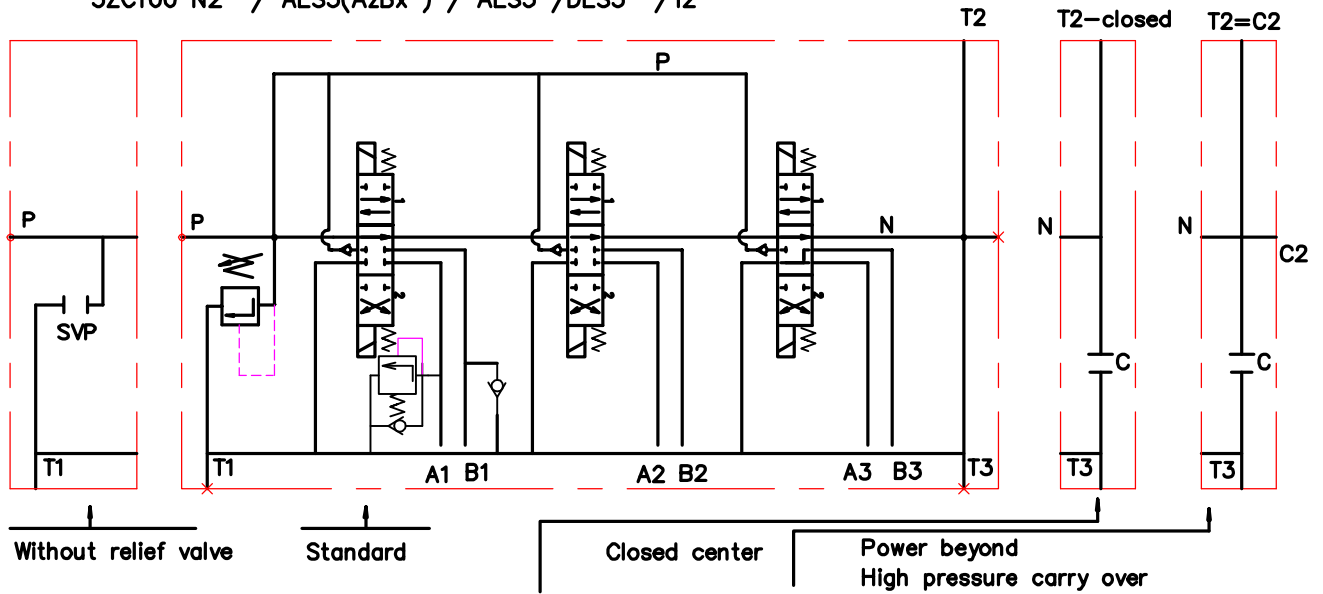

code	напорная секция / inlet cover	
N1	N1 (210 bar)	
N1svp		
N2	N2 (210 bar)	
N2svp		

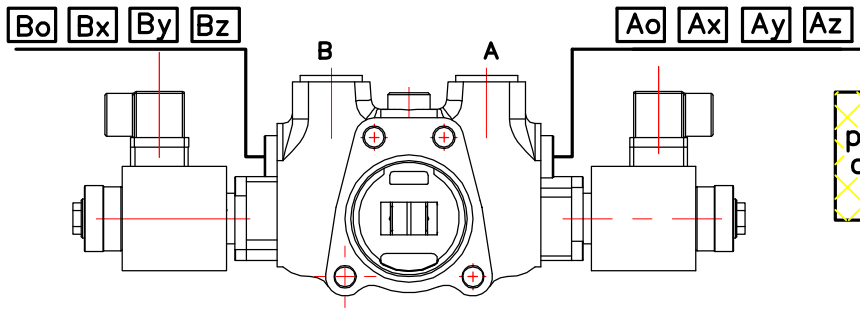

распределительная секция
control valve

code std	виг золотника spool type
A	
B	
C	
D	
E	
F	
G	
H	

code	способ фиксации spool control
ES3	1 0 2
ES1	0 2
ES2	1 0

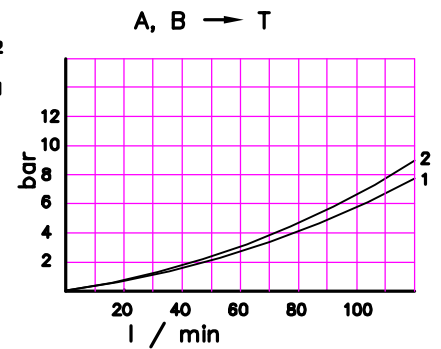
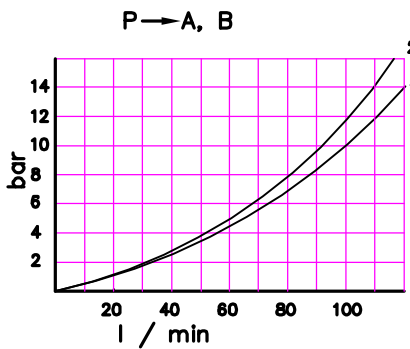
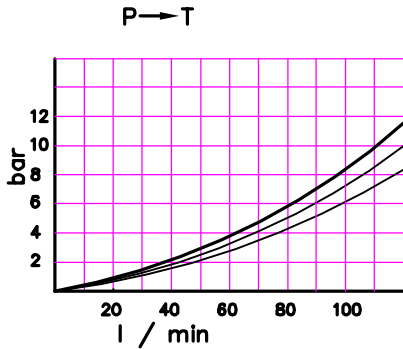

operating diagrams

code	резьбовые отверстия threads			code	резьбовые отверстия threads		
	P, T	A,B	carry over C2		P, T	A,B	carry over C2
G1	G 3/4	G 1/2	G 3/4	S1	SAE 12	SAE 10	SAE 12
G2	G 3/4	G 3/4	G 3/4	S2	SAE 12	SAE 12	SAE 12

Ao	Bo	пробка соответственно к A и/или B (без обозначения) plug for A and/or B (without mark)
Ax	Bx	антикавитационный клапан соответственно к A и/или B anti cavitation valve for A and/or B
Ay	By	предохранительный клапан соответственно к A и/или B secondary pressure relief valve for A and/or B
Az	Bz	шок абсорбер к A и/или B shock absorber valve for A and/or B

вторичные клапаны/ second valves

plug "o"

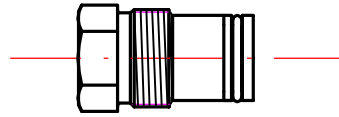

anticavitation valve "x"

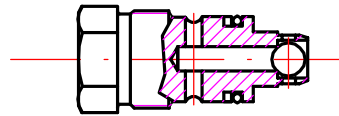

second relief valve "y"

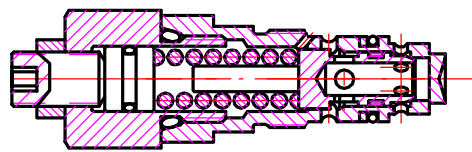

combined part relief and anticavitation valve "z"

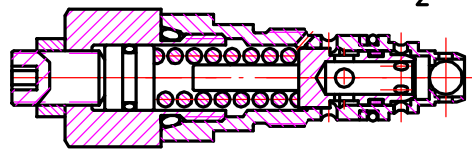

сливная секция
end plate

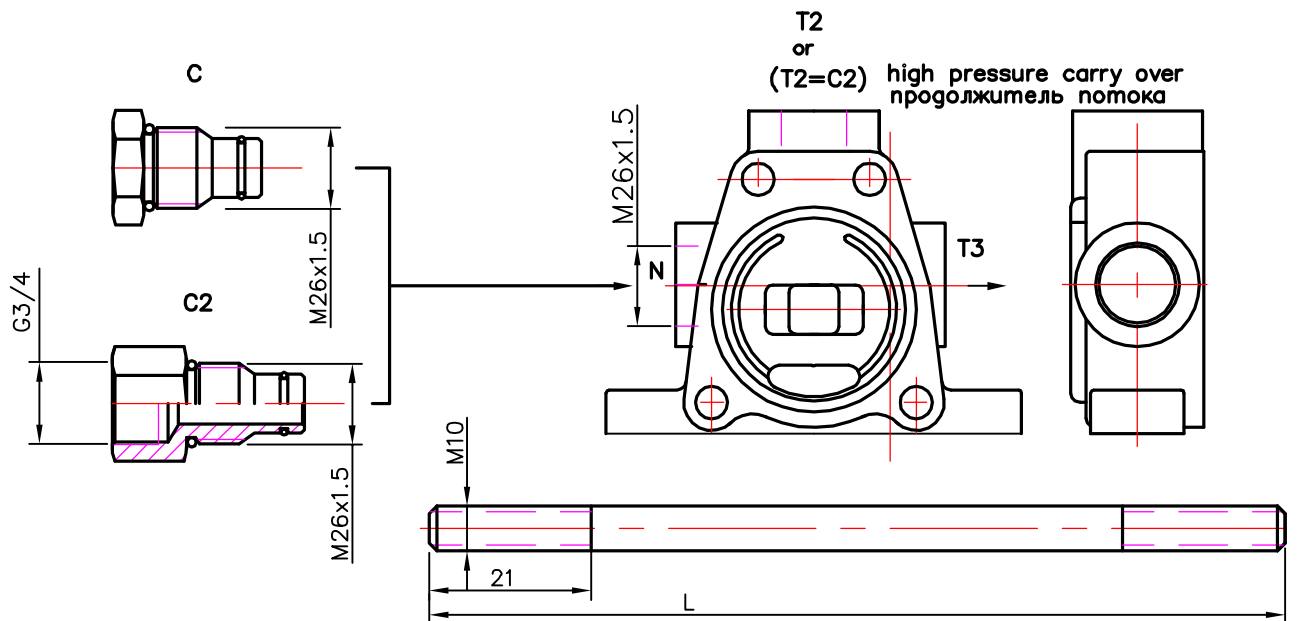

*C - C in port N+plug in T2-closed center
 **(T2=C2)- C in port N-carry over in T2
 ***C2-C2 in port N+Plug in T2- carry over in N

брой золотников number of spools	1	2	3	4	5	6	7	8
L	145	188	230	275	320	360	405	445

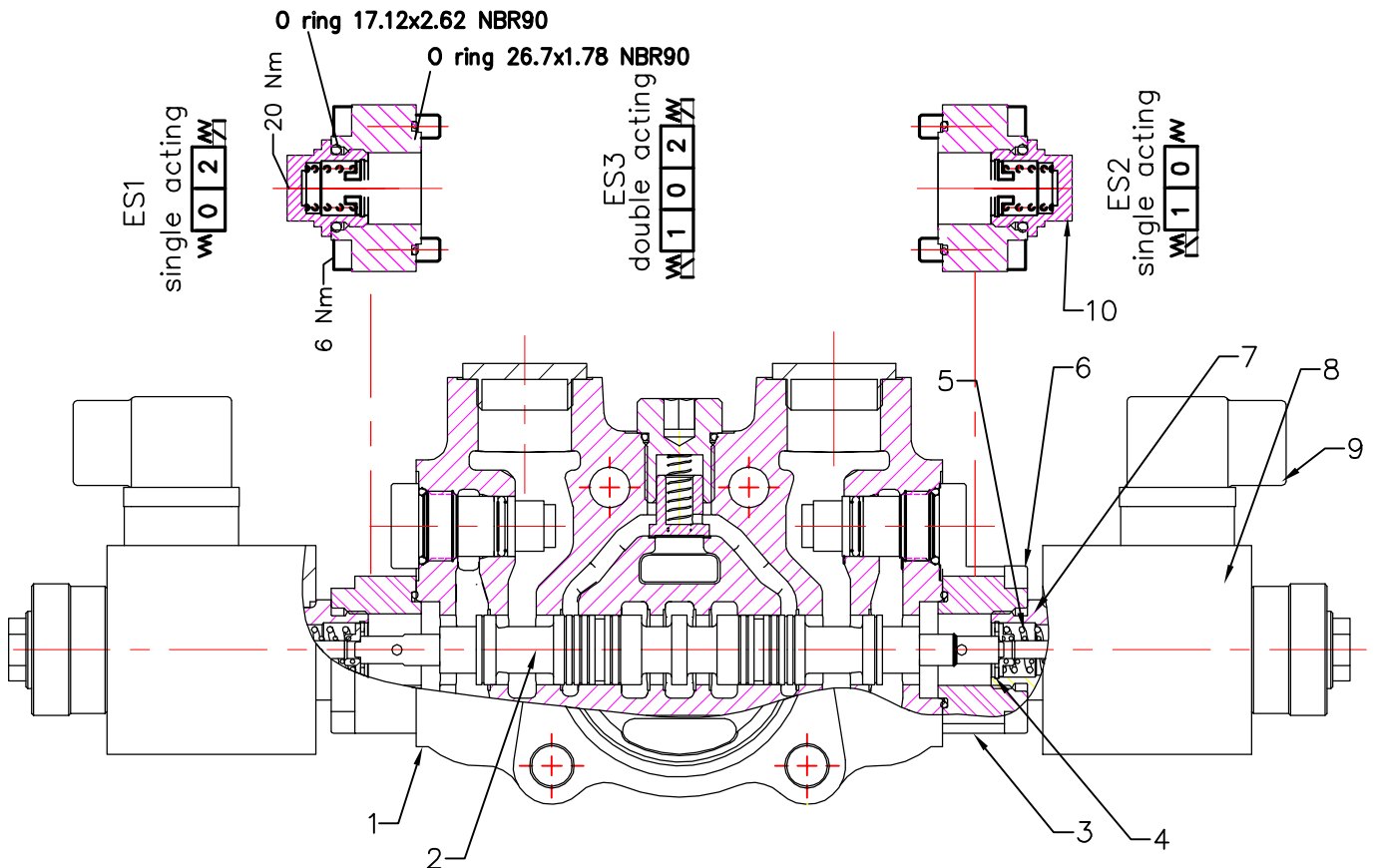

Electric wiring sheme

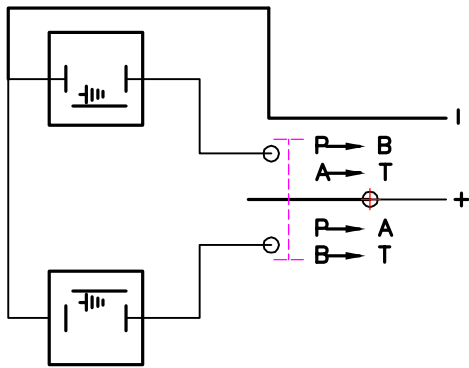

Operating diagram

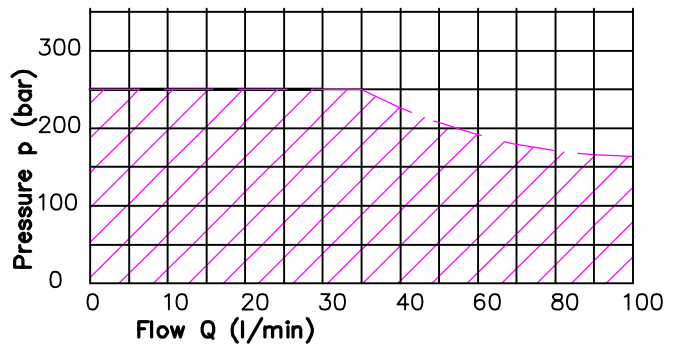

Operating features

2

Технические примечания

2

Control

Internal leakage A(B) → T
 (p=120 bar, Viscosity=32, mm²/s : 20 - 40 μcm/min)
 Fluid temperature - -20 C(short time) ... 80 C
 Max. back pressure on outlet port T - 25 bar (360psi)

Coil

Nominal voltage tolerance ±10%
 Power rating 60 W
 Coil insulance class H
 Duty cycle 100%
 Connector ISO 4400
 Imergency manual override

pos.	Part.No	Description	Quantity
10	558.02.06.00	End cap	...
9	to ISO 4400	Connector	2
8	CD37V...DC	Solenoid coil	2
7	ST701598	Tube	2
6	DIN912	M6x25	2
5	542.02.00.04	Spring	2
4	511.02.00.03	Washer	2
3	511.02.02.00	Intermediate unit	2
2	558.02.01.00	Spool AES	1
1	558.00.00.01...	Body ...	1

Solenoid direct control with spring return to neutral position.

ORDERING EXAMPLE

Section	ZC100	A	ES3	12VDC	G
	1	2	3	4	5

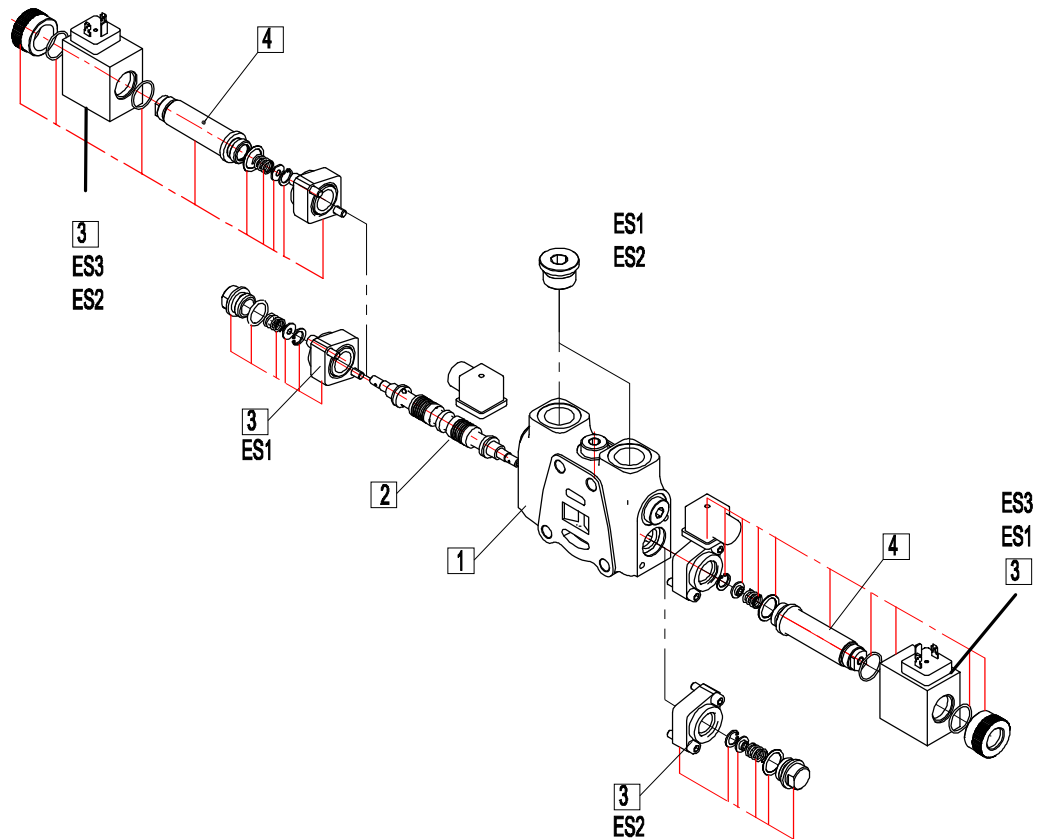

1.Body kit

Type
558.00.00.01 parallel

Description
1 spool

3.Control kit

Type	Description
ES1	Single acting P – A with spring return in neutral position
ES2	Single acting P – B with spring return in neutral position
ES3	Double acting P – A, B with spring return in neutral position

2.Spool options

Type	Description
A	Double acting, 3 positions with A and B closed in neutral position
D	Double acting, 3 positions with A and B open to Tank in neutral position
B	Single acting, 3 positions with A closed in neutral position
C	Single acting, 3 positions with B closed in neutral position

4.Coils

Type	Description
(with connector ISO 4400)	
12VDC	Nominal voltage 12VDC
24VDC	Nominal voltage 24VDC

5.Port threads